

GRID INTERCONNECTION SOLUTIONS FOR WIND POWER PROJECTS



SUCCESS OF A WPP

The Electrical Power generated by the Wind Turbine Generators (WTGs) needs to be brought to the paying customer.

The paying customer is the sole contributor in generating the revenue.

A project is only successful when it starts earning the revenue.

SUCCESS OF A WPP

The Electrical Power generated by an individual WTG within a Wind Park needs to be collected, transmitted and distributed to the individual customer.

If any of the above steps are not properly undertaken, the Wind Project is bound to fail.

Grouping of Wind Turbines

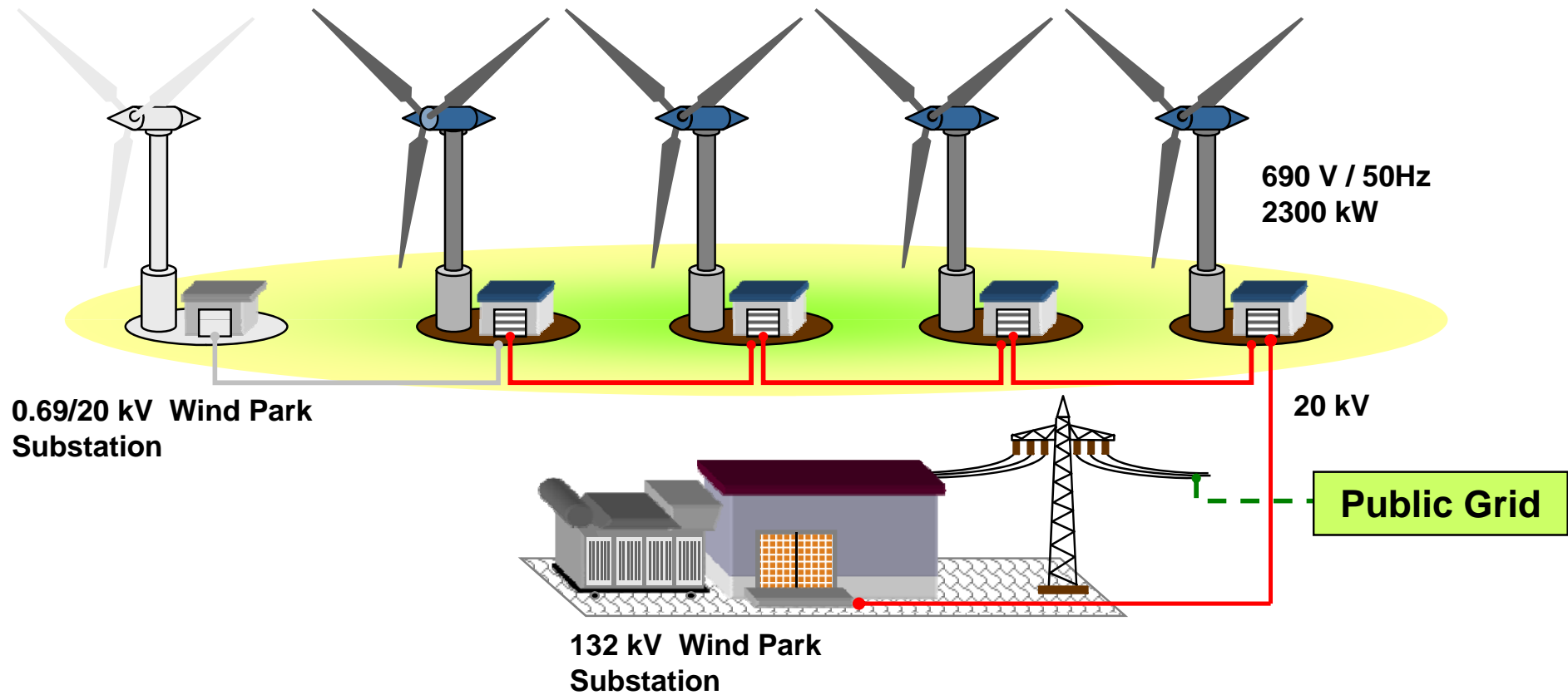

Principal Overview Concept (Line Feeder Arrangement)

21 WTGs, 2.3MW each
 No. of Lines: 5 - 6
 WTGs per Line: 3/5
 Oper. Volt. : $U_N=690V/20\text{ kV}$

Wind park-20kV
 Cable Network

132kV Main Station

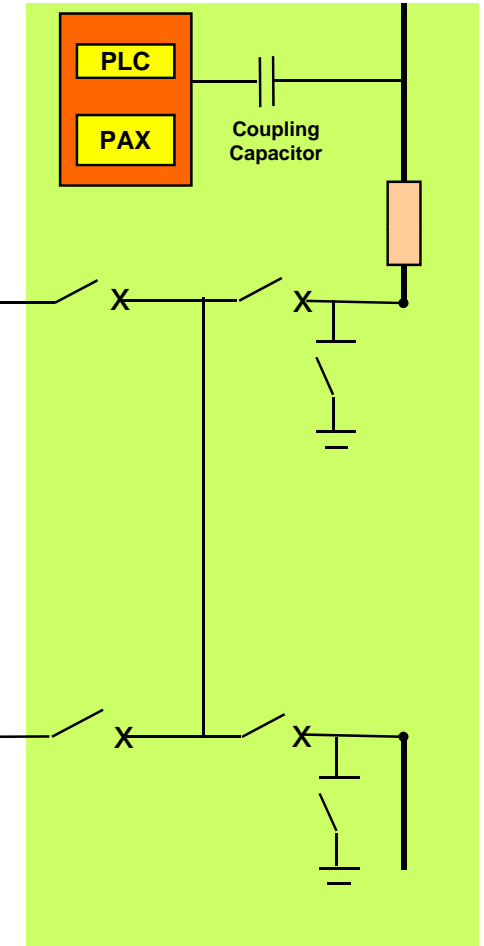
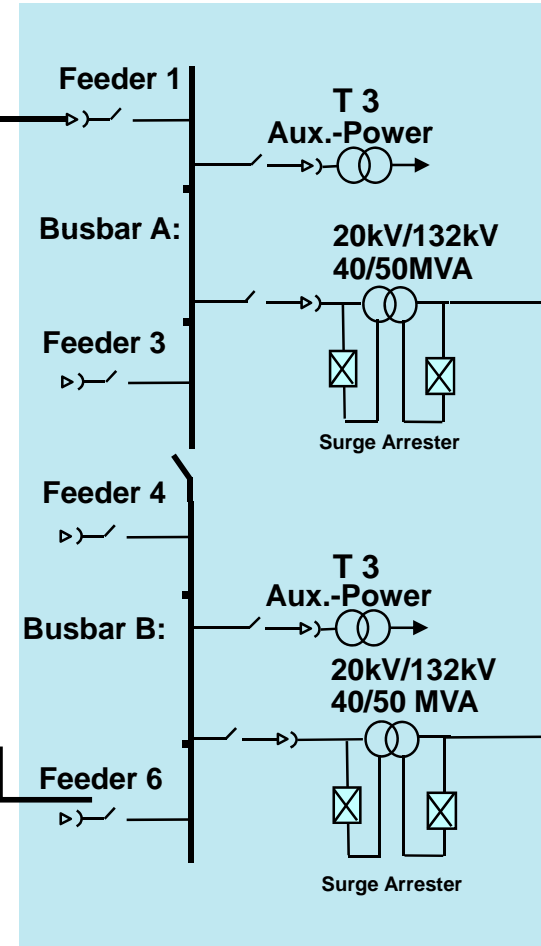
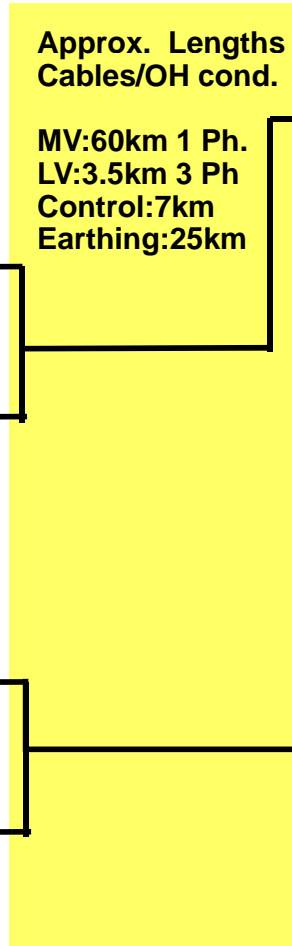
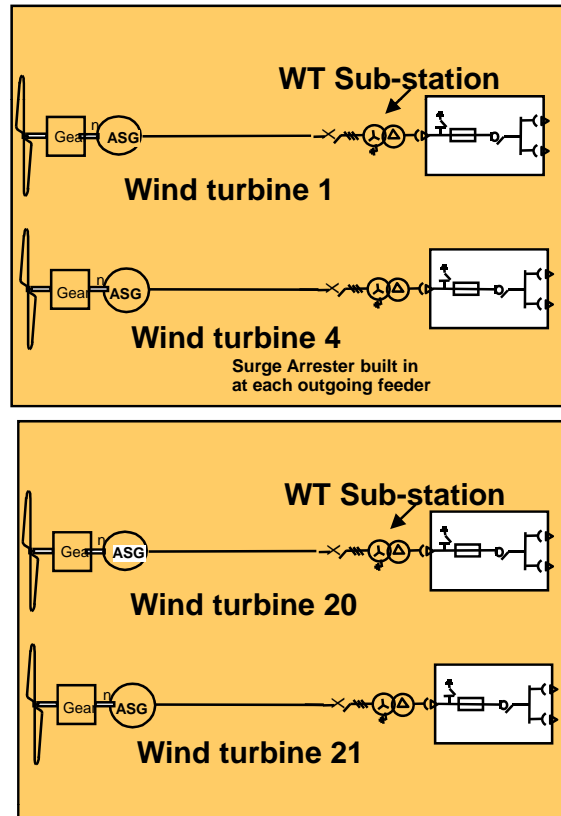

HESCO Grid Network

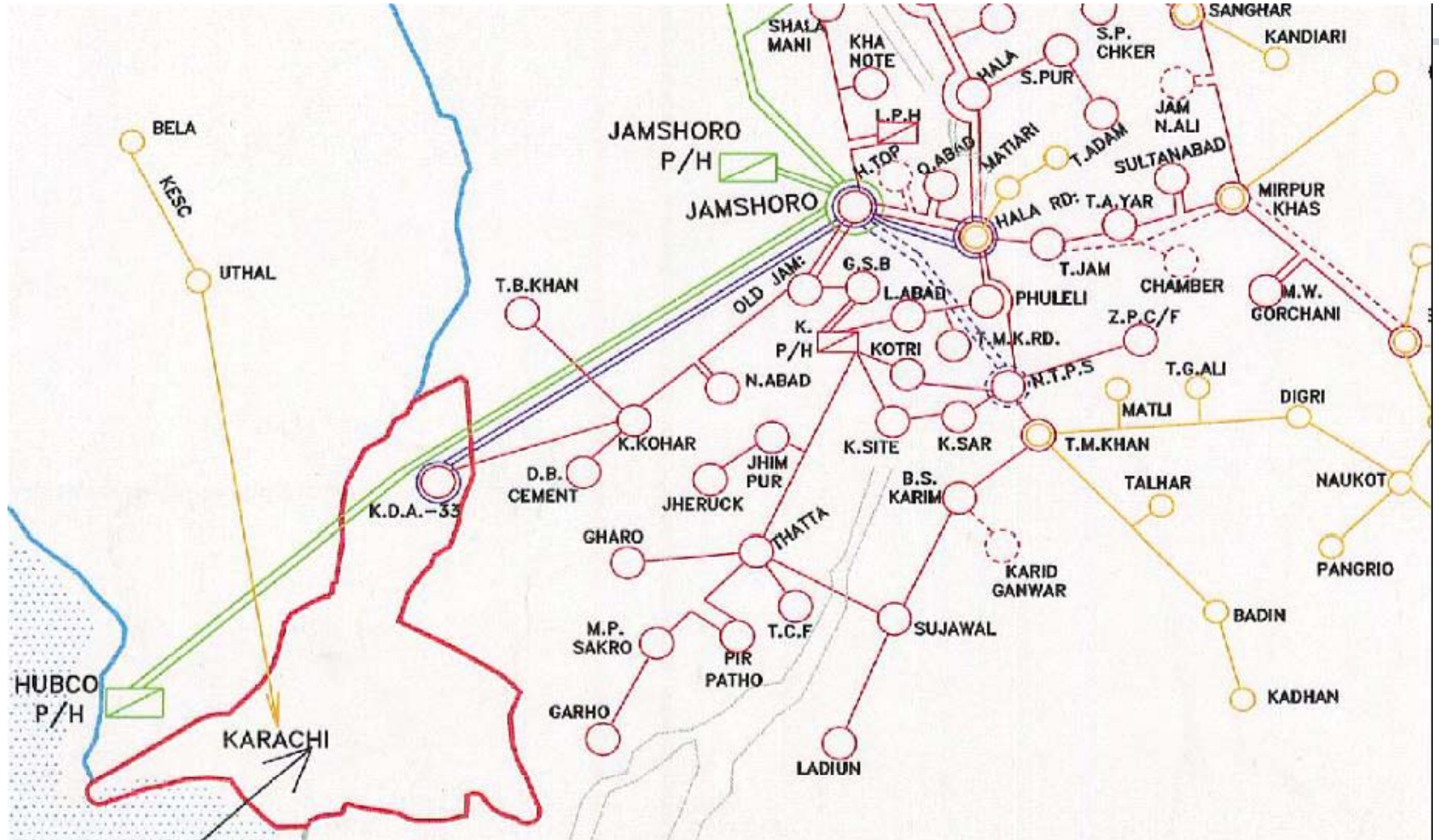

VARIOUS STEPS

Facilitated by the sponsor (AEDB), a WPP is developed by the Investor. However before the power reaches the customer it goes through the following steps:

- 1) WTGs make it available at 690V at the base of the tower**
- 2) Stepped up to 20kV in the WTG substation and goes through the collection system
- 3) Stepped up to 132kV at the WPP main station and fed into the utility operators network (HESCO).
- 4) Fed into the transmission company's (NTDC) network at 220kV. The transmission company is also the purchaser in our case.
- 5) The energy is delivered to the consumers at appropriate voltage levels by various DISCOs.
- 6) The generation, transmission and distribution charges are part of the tariff determined by the regulator (NEPRA) and paid by the consumer.

STRENGTH OF A NETWORK

Network is strong if S/Pn ratio is > 25 at take off

Network is weak if S/Pn ratio is < 25 at take off

At Gharo: **S/Pn = 6** i.e. network is very weak

At Jhimpir: **S/Pn = 17** i.e. network is weak

CONCLUSION:

Our HESCO Network at the point of common coupling is weak.
Network can be strengthened:

- **by adding more generation capacity into the network (conventional eg: coal based generation)**
- **by using WTGs which can support the grid (type D with full converter)**

Overview of wind turbine concepts (power quality characteristics)

<p>Type A Fixed speed</p>	<ol style="list-style-type: none"> 1) Fixed speed (variation by slip upto 1%) 2) Reactive power control: static, by capacitors, SVC 3) Power quality: high power fluctuations 4) Power Factor: 0.9 inductive
<p>Type B Variable slip</p>	<ol style="list-style-type: none"> 1) Variable speed (variation by rotor resistance upto 10%) 2) Reactive power control: static, by capacitors, SVC 3) Power quality: smoother than type A, harmonics 4) Power Factor: 0.99 inductive to 0.99 capacitive
<p>Type C Doubly-fed IG</p>	<ol style="list-style-type: none"> 1) Variable speed 2) Reactive power control: dynamic, converter 30% of generator independent of active power within converter range. 3) Power quality: smooth output, low harmonics 4) Power Factor: 0.95 inductive to 0.95 capacitive
<p>Type D Full converter (IG/PM/SG)</p>	<ol style="list-style-type: none"> 1) Variable speed 2) Reactive power control: dynamic, converter 100% of gen. independent of active power within converter range 3) Power quality: smooth output, low harmonics 4) Power Factor: 0.9 inductive to 0.9 capacitive.

- **Load Flow Studies**
- **Short-circuit Studies**
- **Stability Studies**
- **Power Quality Analysis**

The impact of WPP on the Network and vice versa are studied under following conditions:

- **Varying operating conditions of WPP from 100% to 0% output**
- **Network conditions of peak load and off peak load with high hydro power availability and low hydro (high thermal) power generation.**
- **The impacts are to be studied in steady state as well as dynamic (disturbed) conditions**

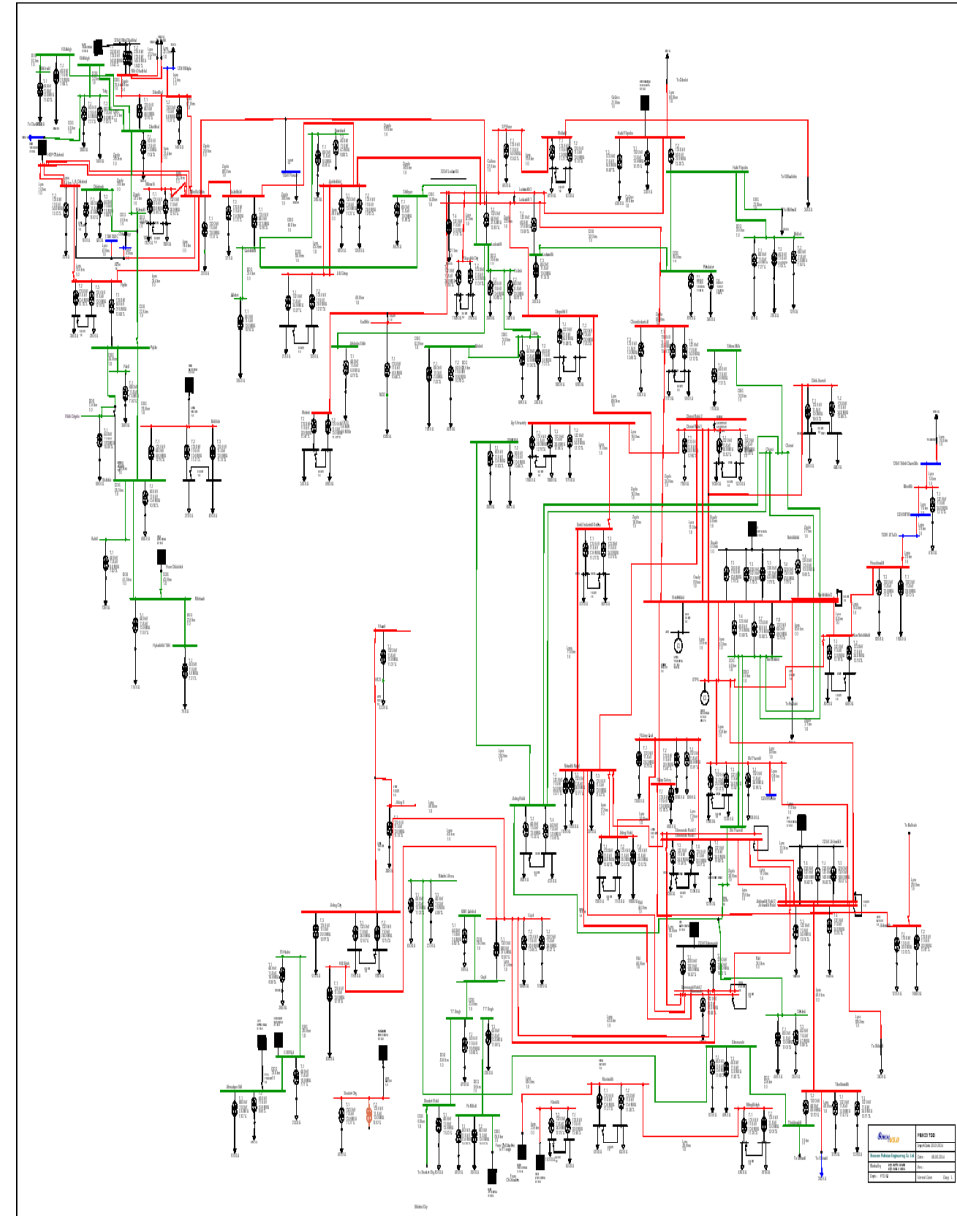

Network Studies

Load Flow Studies

- Calculation of voltages, currents and power over the whole network.
- Loading of electrical equipments during normal operation.
- Weak-point Analysis.

Short Circuit Analysis

- To determine the maximum and minimum values at 3-phase, 2-phase & 1-phase faults.
- Short Circuit study used for;
 - ✓ Dimensioning of switching devices
 - ✓ Protection Coordination

Network Studies

Stability Analysis

- To determine the impact of Wind Power on the Grid.
- Dynamic analysis to calculate the voltage fluctuations.
- Transient stability of the wind turbine generators.

Power Quality Analysis

- System Harmonics.
- System Resonance
- System Flicker
- Unbalanced Conditions

Critical Points in Grid Code Release Report

No.	Topic	Agreement
1	Voltage Control, Reactive Power and Power Factor.	Wind Turbine Generators generally cannot provide Reactive Power to the Grid. However Wind Power Plants should be able to operate at 0.95 power factor (leading & lagging) at the point of common coupling.
2	Frequency Control (reserve margins, load rejection)	Wind Power plants cannot provide dynamic response to variation in load demand and thus cannot instantaneously change its Active Power output. Similarly output from wind turbines in operation cannot be reduced at will and wind turbines will need to be shut down for load rejection upon Despatch from the Grid System Operator.
3	Black Start Islanded operation	Wind Power plants are not capable of providing black start or support islanded systems.
4	Low Voltage Ride Through (LVRT)	For the initial Wind Farms (upto 1000MW), LVRT of 180 ms at 0.3 p.u. at point of common coupling has been agreed.

Low Voltage Ride Through (LVRT)

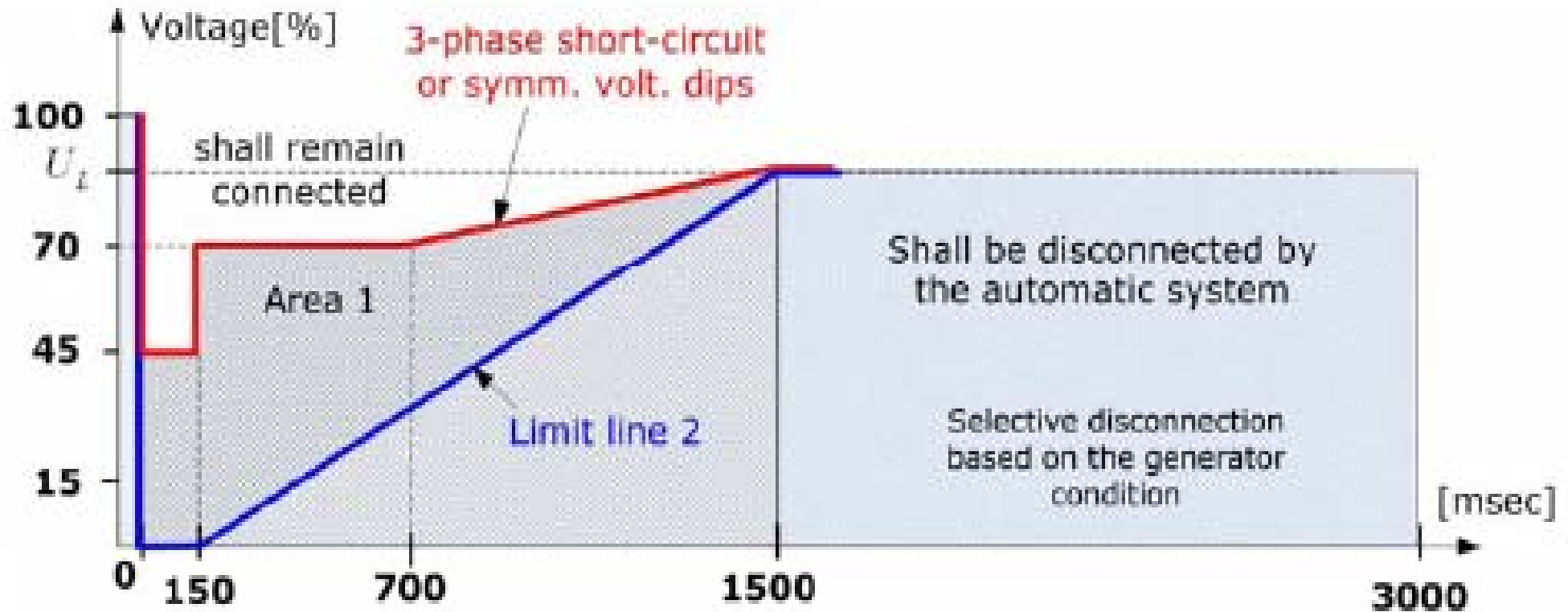

Voltage limits for disconnection of generating units in the case of faults in the grid.

LVRT in various Grid Codes

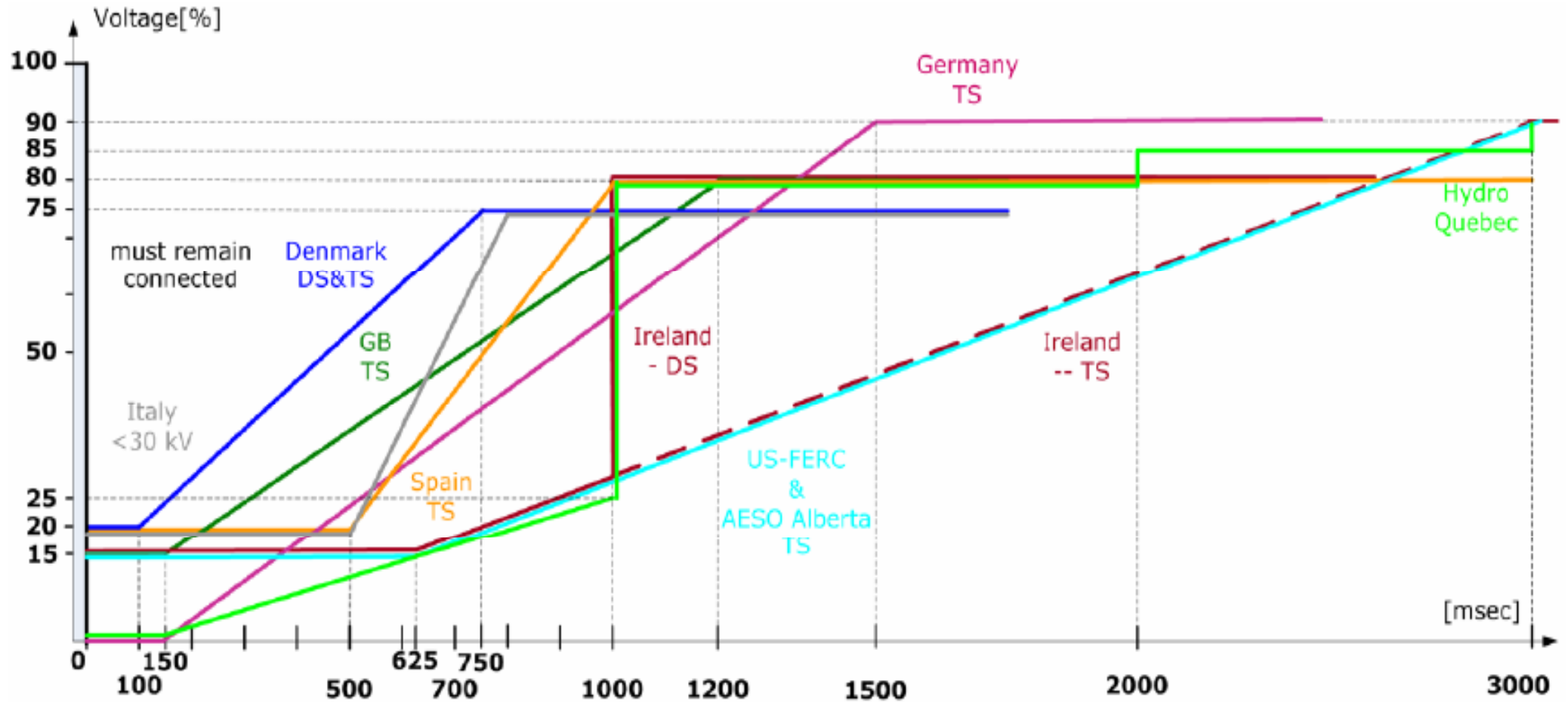

Summary regarding fault ride through capability of wind turbines/farms in National Grid Codes.

LVRT Capability Requirement - Summary

Summary of ride-through capability for wind turbines/farms in different national grid codes.

Country	Voltage Level	Fault ride-through capability				
		Fault duration	Voltage drop level	Recovery time	Voltage profile	Reactive current injection
Denmark	DS	100 msec	25%U _r	1 sec	2, 3-ph	no
	TS	100 msec	25%U _r	1 sec	1, 2, 3-ph	no
Ireland	DS/TS	625 msec	15%U _r	3 sec	1, 2, 3-ph	no
Germany	DS/TS	150 msec	0%U _r	1.5 sec	generic	Up to 100%
Great Britain	DS/TS	140 msec	15%U _r	1.2 sec	generic	no
Spain	TS	500 msec	20%U _r	1 sec	generic	Up to 100%
Italy	> 35 kV	500 msec	20%U _r	0.3 sec	generic	no
USA	TS	625 msec	15%U _r	2.3 sec	generic	no
Ontario	TS	625 msec	15%U _r	-	-	no
Quebec	TS	150 msec	0%U _r	0.18 sec	Positive-sequence	no

Voltage dip under fault Condition

- Short circuit power of WTGs is low.
- In case of short circuit near the wind farms, Grids connected in surrounding with high short circuit power will have major contribution to short circuit current resulting in excessive voltage dips over a large area.
- *This may result in “Blackout”*
- Protection relays should be reset accordingly to isolate the fault.

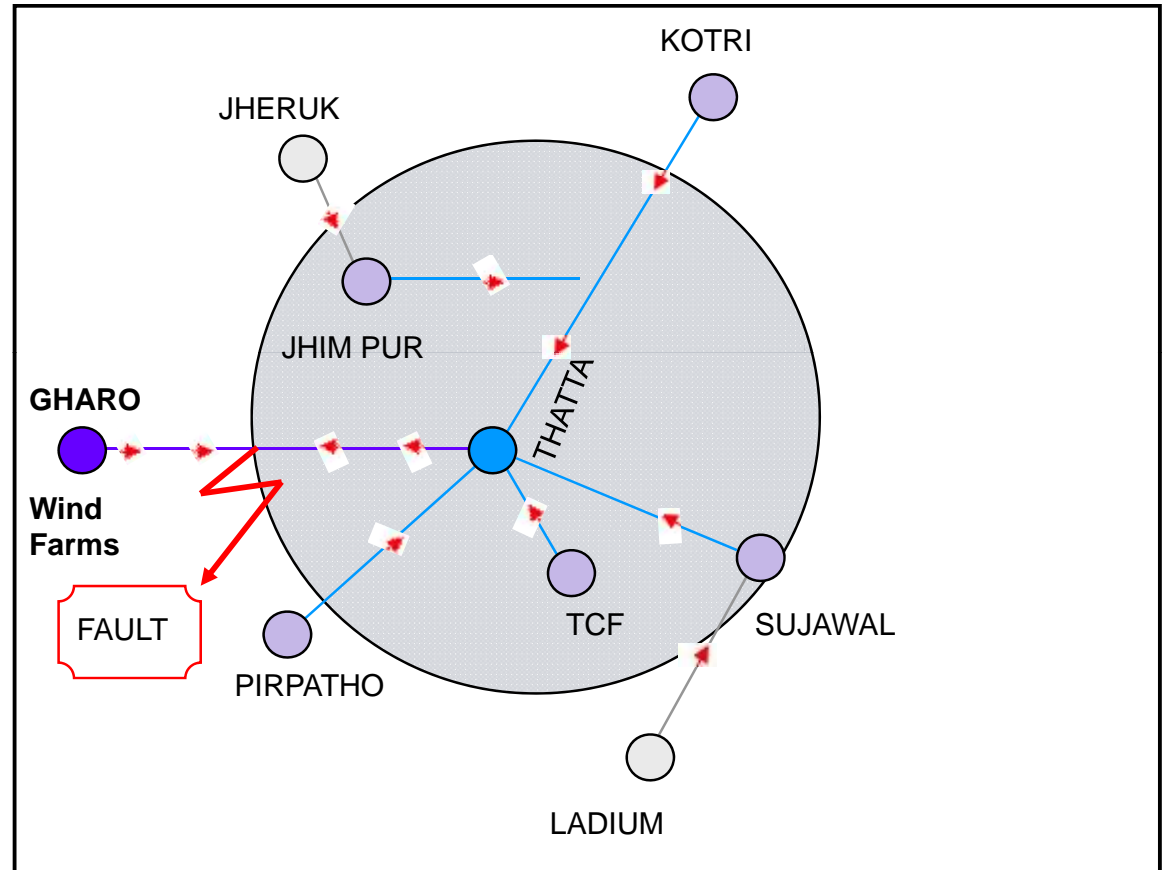

○ Area of voltage dip in case of fault near GHARO

OTHER RECOMMENDATIONS TO SUPPORT WTGs AND THE UTILITY NETWORK

Biogas/Biodiesel run power plants of 15% WPPs capacity should be installed in the Public Sector or under Private/Public Partnership to provide ancillary services for the WPPs such as

- **VAR Compensation**
- **Blackstart**

A 50MW biogas/biodiesel plant can be established near the cattle colony Karachi to support WPPs at the Khuttikun and Jhimpir site.

According to a bankable feasibility study, it is possible to produce biogas for continuous 50MW Electrical Power generation from cow dung from Karachi cattle colony.

Power for ancillary support should also be produced by using biodiesel from jatofra to be planted in the Wind Farms.

Thank
You

The information provided in this presentation contains general descriptions or characteristics of performance which in case of actual use may not always apply as described or which may change as a result of further development of the products. An obligation to provide the respective products/services and their characteristics shall only exist if expressly agreed in the terms of contract. Availability and technical specifications are subject to change without notice. The trademarks used are owned by Siemens AG or their respective owners.

Basic Concept of Sub-stations for Wind Turbines

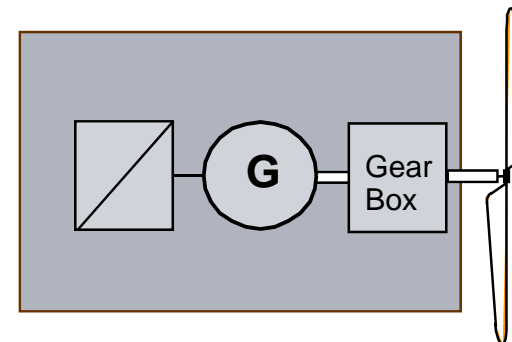
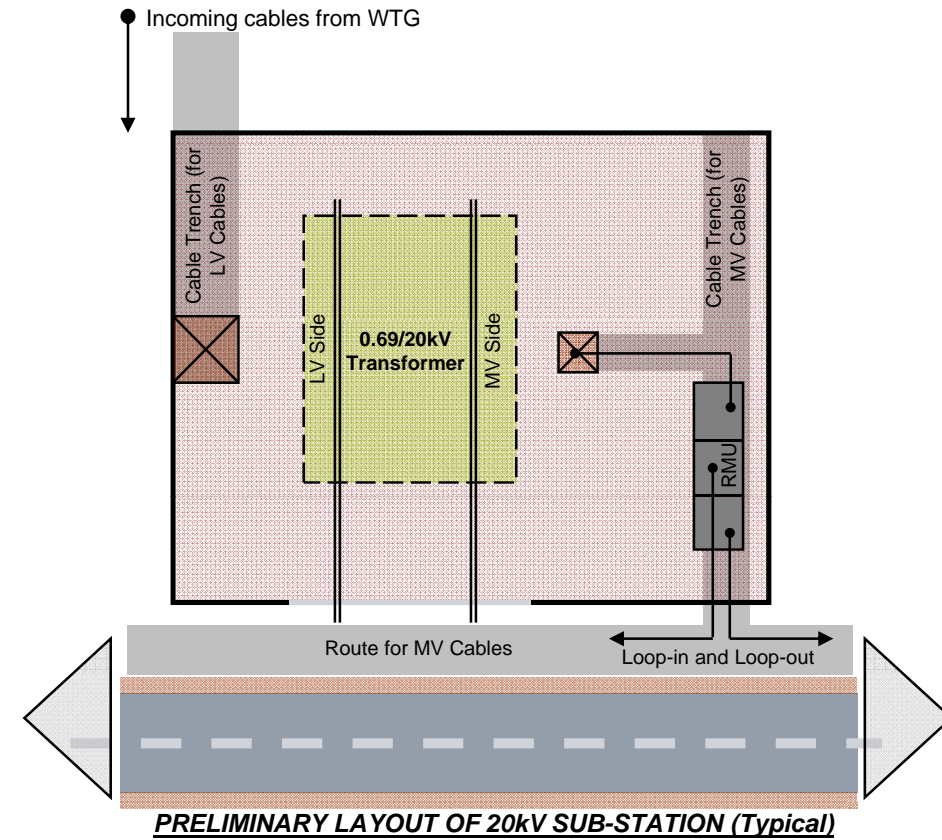
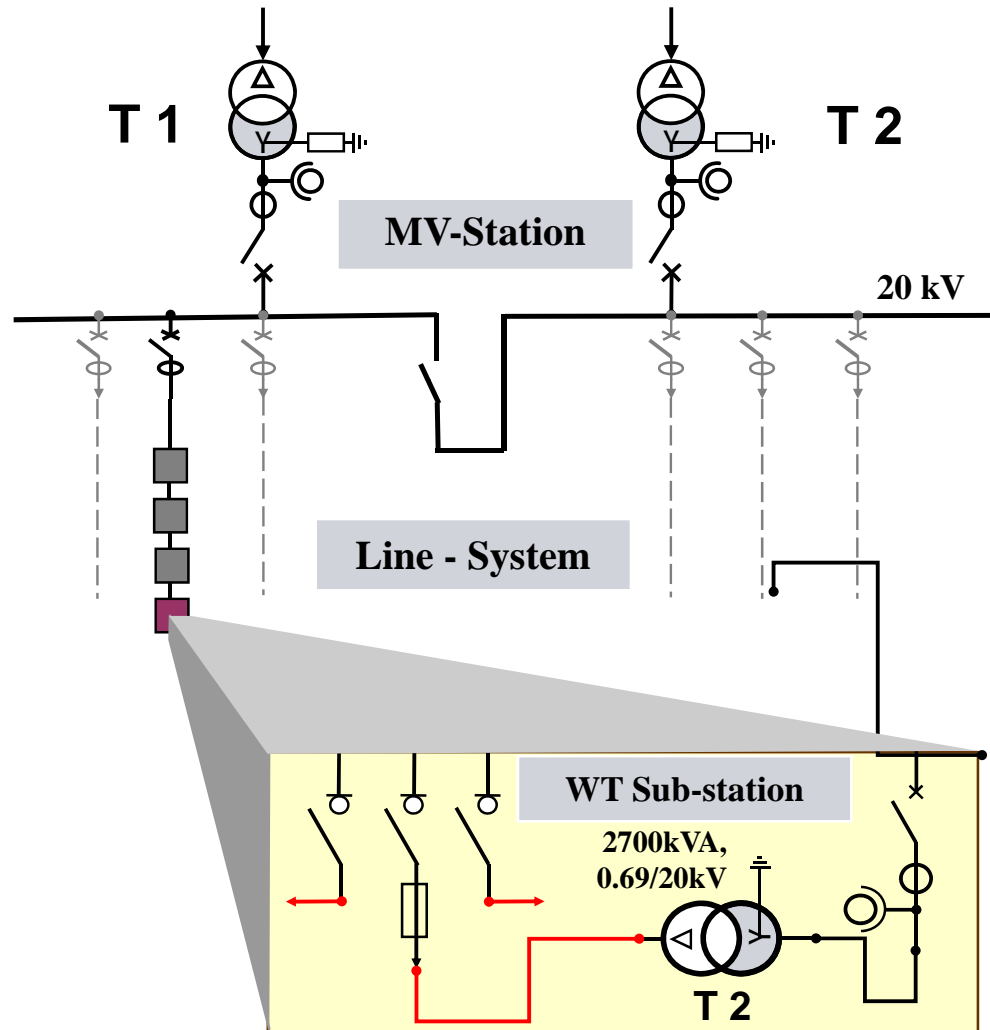

Collection System Voltage. Why 20kV?

The limiting figure is the maximum operating voltage of the equipment. This in accordance with IEC 24 kV.

- **Within this framework it is possible to operate with a nominal voltage of 20 kV or 22 kV. The decision is necessary to select the right rating of the transformer and the taps.**
- **20 kV level is recommended to ensure a sufficient gap between operating voltage and design voltage under all operating conditions considering:**
 - ✓ **long radial feeder**
 - ✓ **switching operations**
 - ✓ **filter circuits**
 - ✓ **operational experience in other wind farms**
- **The argument for 22 kV "loss reduction due to lower current level" is not considered as to be first priority compared to distribution networks and the technical benefits listed before.**

SUCCESS OF A PROJECT - II

All the stakeholders need to operate in unison to make the success happen

STAKEHOLDERS

SPONSOR DEVELOPER	AEDB GP, BEL, FFC, TENAGA, SAPPHIRE ,.....
LENDER	IFC, ADB, BANKS,
SUPPLIER	SIEMENS, NORDEX, GE,
UTILITY OPERATOR ENERGY PURCHASER	HESCO NTDC
REGULATOR	NEPRA

132kV Grid Station

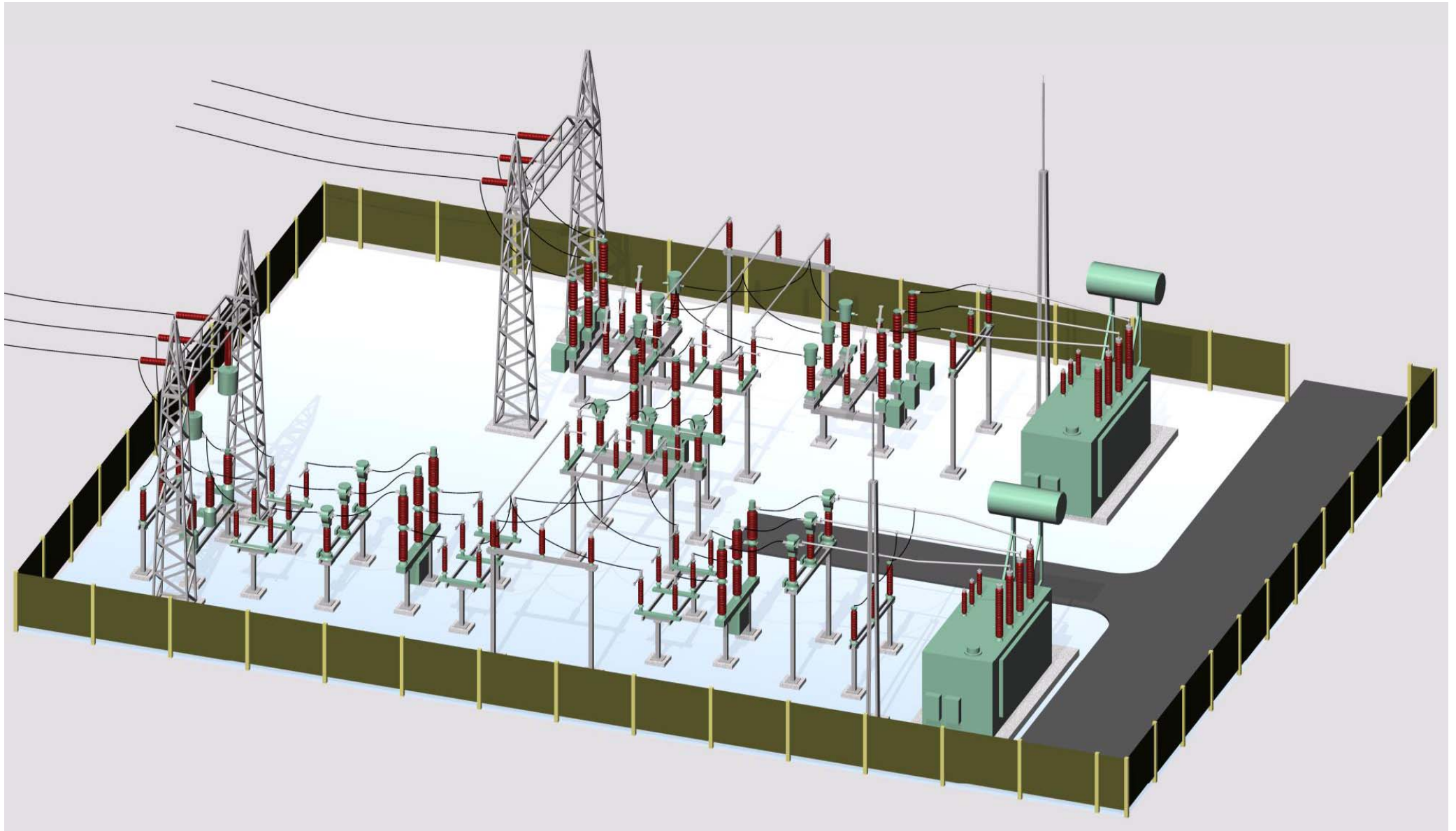

Reactive Power - Concepts

Instantaneous power $p = V_{\max} I_{\max} \cos \omega t \cos(\omega t - \theta)$	
$p = \frac{V_{\max} I_{\max}}{2} \cos \theta (1 + \cos 2\omega t) + \frac{V_{\max} I_{\max}}{2} \sin \theta \sin 2\omega t$	
Instantaneous active power $\frac{V_{\max} I_{\max}}{2} \cos \theta (1 + \cos 2\omega t)$	Instantaneous reactive power $\frac{V_{\max} I_{\max}}{2} \sin \theta \sin 2\omega t$
Average active power $P = VI \cos \theta$ called simply active power	Average reactive power $= 0$ ignored usually.
Maximum instantaneous active power $VI \cos \theta$ ignored usually as is the same quantity as P	Maximum instantaneous reactive power $Q = VI \sin \theta$ called simply reactive power .

Cable Requirements (50MW WPP)

21 X 2.3MW WTGs

MV Cable:

24kV Polymer XLPE isolated 3 core metallic screened cables with longitudinal watertight screen area and radial watertight by a polymer laminated sheath of following types suitable for laying in wet and sometimes flooded ground (brackish water):

- **NA2XS(FL)2Y or equivalent for Aluminium conductor**
- **N2XS(FL)2Y or equivalent for Copper conductor**

- **Al cables preferred due to cost issue.**

- **Sizes: 120, 240 & 400 sq mm (in varying length)**

- **Total requirements: 60 – 70km **single core****

Cable Requirements (50MW WPP)

21 X 2.3 MW WTGs



LV Cable:

690V Cu cable NYY-O Single core

Cross sections of 240 sq mm & 630 sq mm

The cable should be suitable for laying in wet & sometimes flooded water (brackish water).

Length: 03 – 3.5 km approx.

Earthing Conductor:

Bare Cu conductor 120 sq mm & 90 sq mm

Length: 20 - 25 km approx.

Control cables:

Multi core control cables in different cross sections

Length: 05 – 07 km approx.

SWT-2.3-101

Electrical Specifications



Generator

Type	Asynchronous
Nominal power	2300kW
Speed range	600 - 1800 rpm
Nominal voltage	750V at 1550 rpm
Nominal current	2070 A
Frequency	16,5 - 60 Hz
Protection	IP 54

Generator Protection

Insulation class	F
Winding temperatures	2 x 3 PT100 sensors
Bearing temperatures	1 PT100 at each bearing
Bearing insulation	Insulation at both bearings
Grounding brush	On drive end

Grid Requirements

Nominal grid frequency	50 Hz
Minimum voltage	90 % of nominal
Maximum voltage	110 % of nominal
Minimum frequency	94 % of nominal
Maximum frequency	104 % of nominal
Maximum current asym.	5%
Max 1 s. short circuit level at controller's grid	
Terminals (690 V)	40 kA
Min. 1 s short circuit level at controller's grid terminals (690 V)	5 x Pn
Grid error numbers	Max. 300 per year

Reactive Power - Concepts

$$\bar{V}_S = \bar{V}_R + \bar{I}_R \bar{Z} - \frac{\bar{V}_R \bar{Z}}{X_C}$$

$$\bar{I}_S = \frac{\bar{V}_S}{X_C} + \frac{\bar{V}_S - \bar{V}_R}{\bar{Z}}$$

$$Q_S = \frac{V_S}{Z^2} \left[V_S X_L - X_L V_R \cos \theta + R V_R \sin \theta - \frac{V_S}{X_C} Z^2 \right]$$

$$Q_S = \frac{V_S^2 - V_S V_R \cos \theta}{X_L} - \frac{V_S^2}{X_C}$$

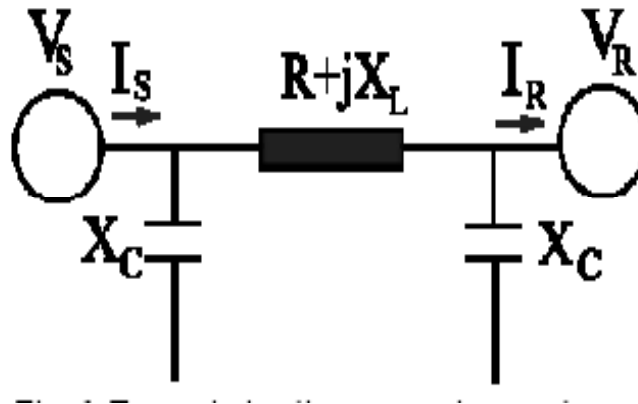
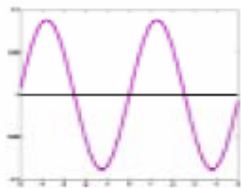

$$\bar{V}_R = \bar{V}_S - \bar{I}_S \bar{Z} + \frac{\bar{V}_S \bar{Z}}{X_C}$$

$$\bar{I}_R = -\frac{\bar{V}_R}{X_C} + \frac{\bar{V}_S - \bar{V}_R}{\bar{Z}}$$

$$Q_R = \frac{V_R}{Z^2} \left[-V_R X_L + X_L V_S \cos \theta - R V_S \sin \theta + \frac{V_R}{X_C} Z^2 \right]$$

$$Q_R = \frac{-V_R^2 + V_S V_R \cos \theta}{X_L} + \frac{V_R^2}{X_C}$$

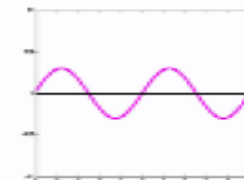

$$\Delta Q_{loss} = Q_S - Q_R$$

$$Q_S - Q_R = \frac{V_S^2 + V_R^2}{X_L} - \frac{2V_S V_R \cos \theta}{X_L} - \frac{V_S^2 + V_R^2}{X_C}$$

Approach Road

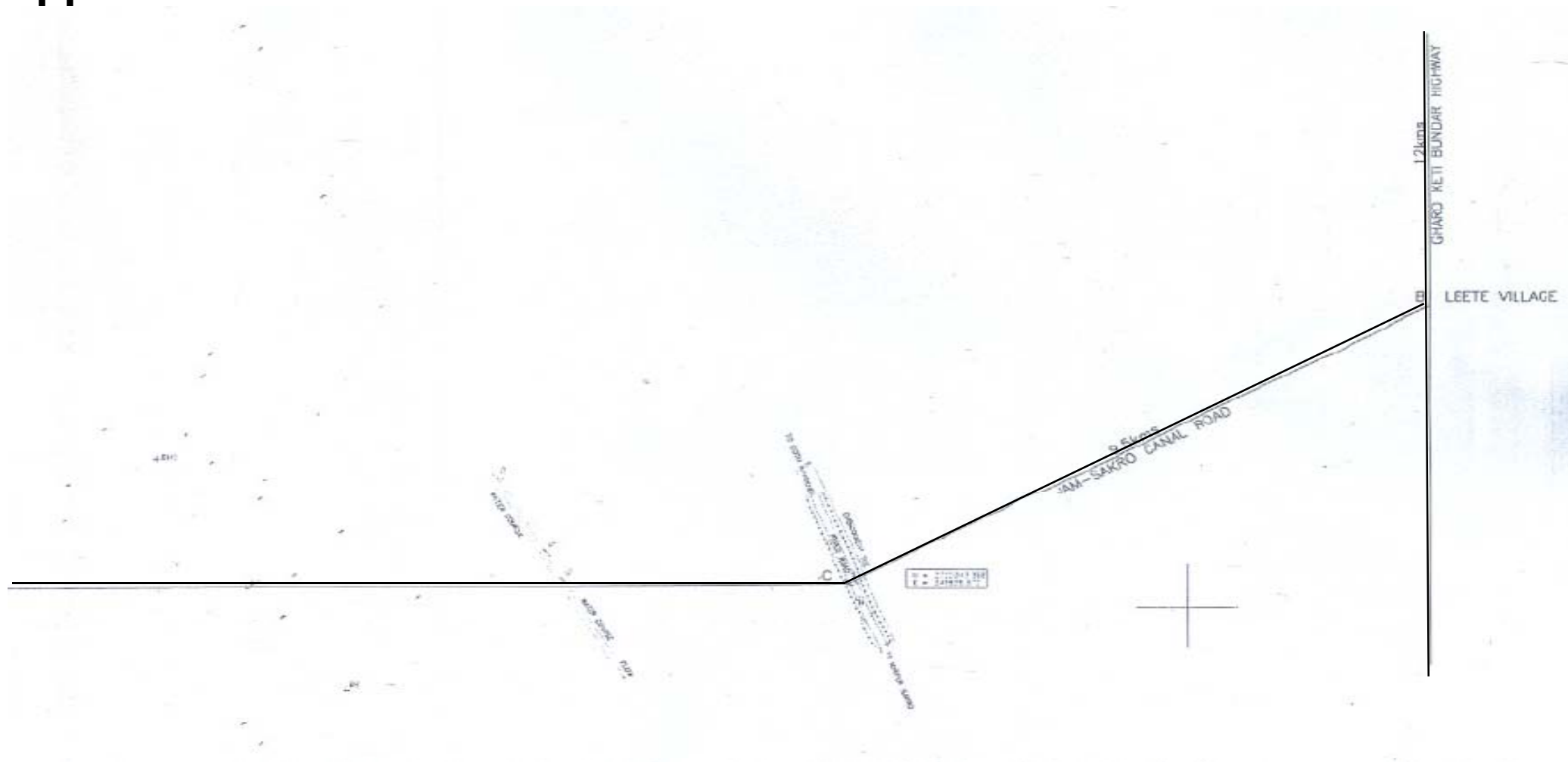

Turbine Foundation

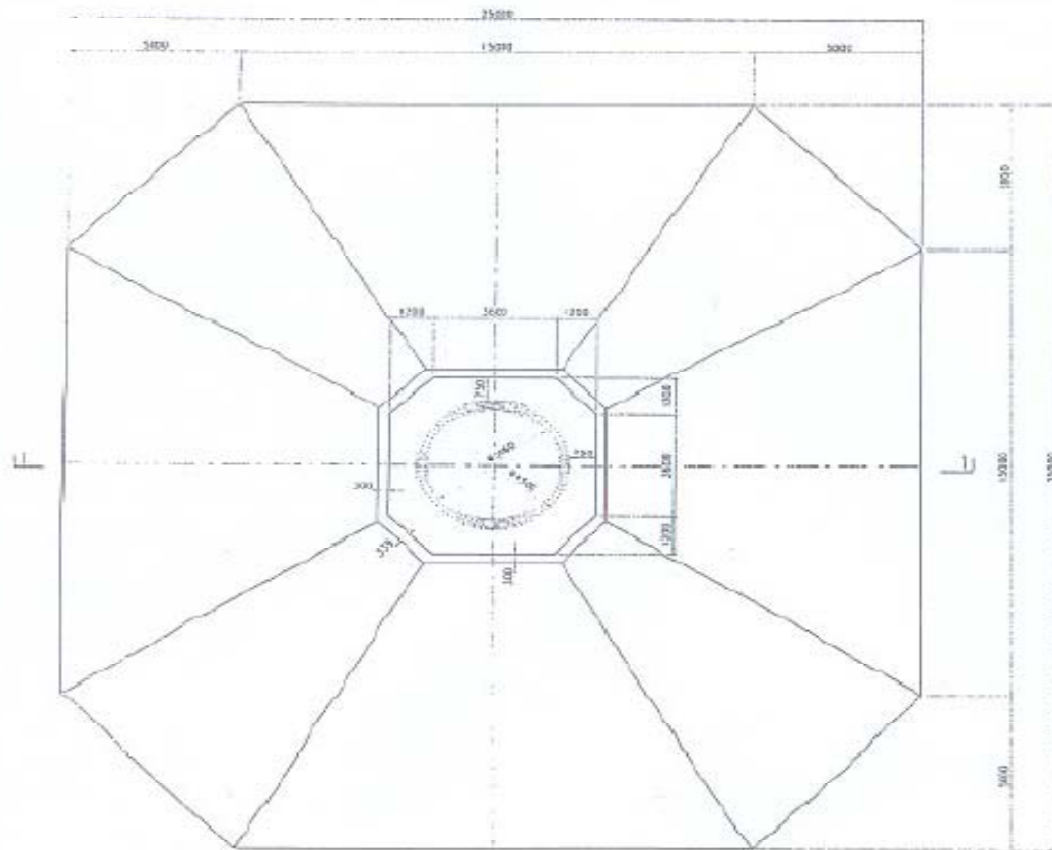
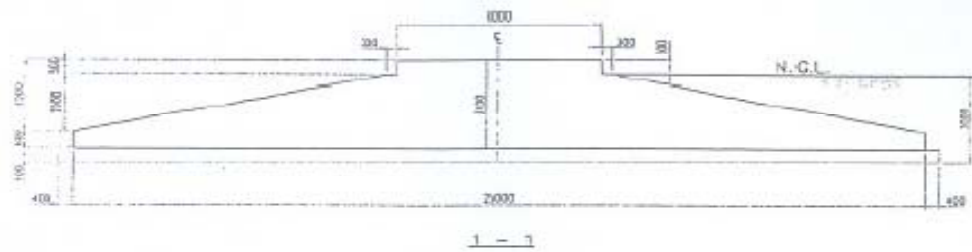

FOUNDATION LAYOUT PLAN
(OPTION 1)

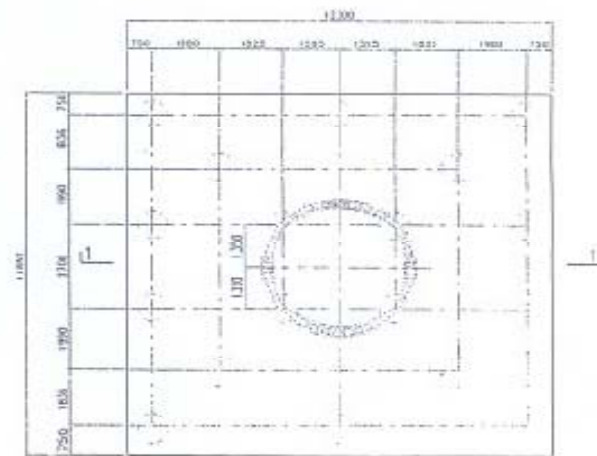
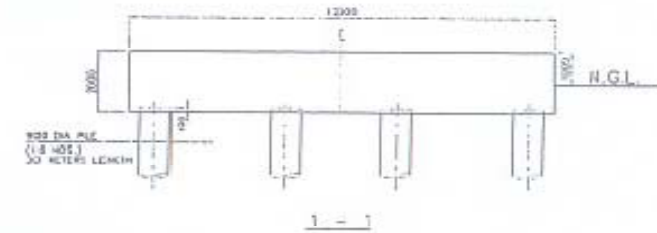

PILE FOUNDATION LAYOUT PLAN
(OPTION II)

Road And Culverts

